

GEORGE A. GRAY, Jr.

Improvement in Railroad Car-Axle Lathes.

No. 114,670.

Patented May 9, 1871.

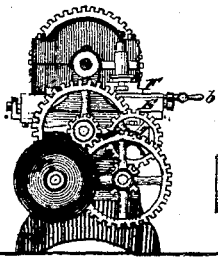

Fig. 2.

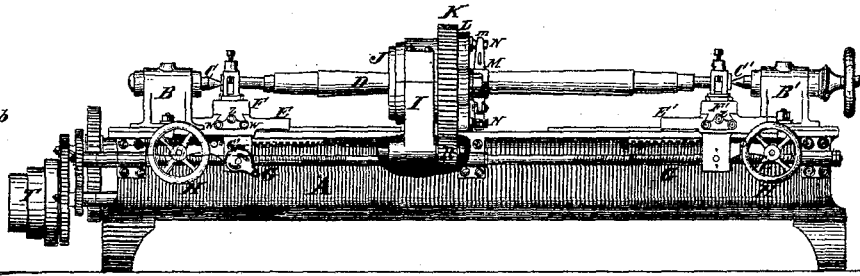

Fig. 1

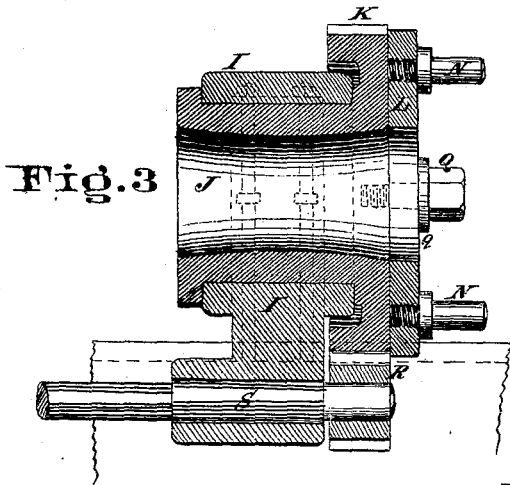

Fig. 3

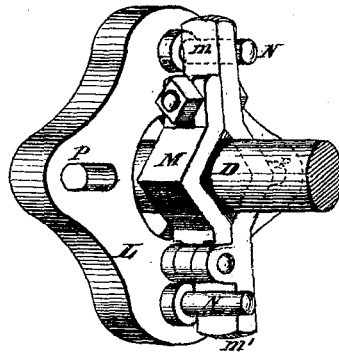

Fig. 4

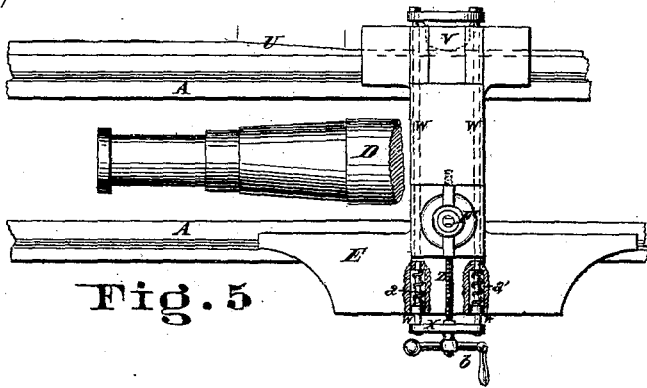

Fig. 5

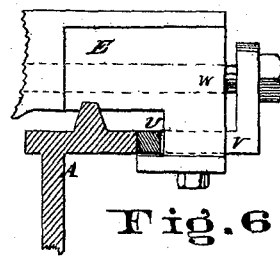

Fig. 6

Attest

Henry Millward
Deitha H. Layman

Inventor

Geo. A. Gray, Jr.
By H. Millward
Attorney

GEORGE A. GRAY, Jr.

Improvement in Railroad Car-Axle Lathes.

No. 114,670.

Patented May 9, 1871.

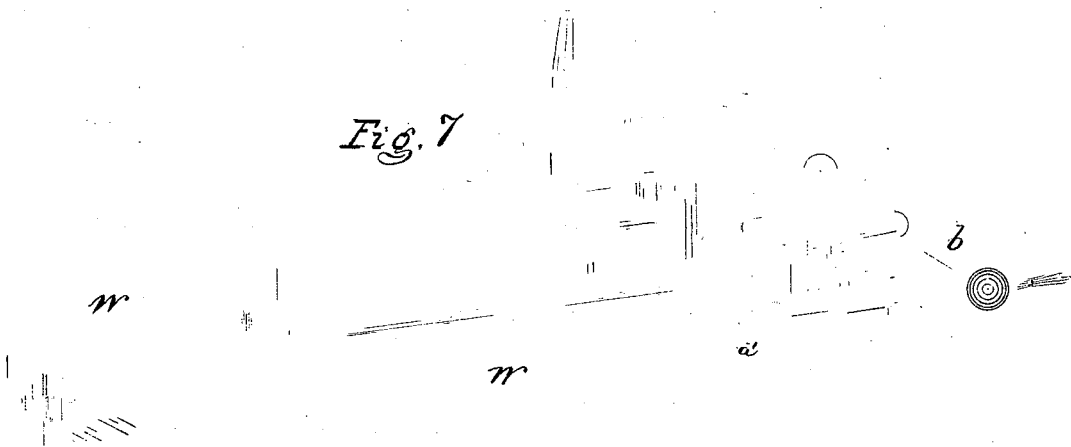

United States Patent Office.

GEORGE A. GRAY, JR., OF CINCINNATI, OHIO.

Letters Patent No. 114,670, dated May 9, 1871.

IMPROVEMENT IN RAILROAD-CAR-AXLE LATHES.

The Schedule referred to in these Letters Patent and making part of the same.

To all whom it may concern:

Be it known that I, GEORGE A. GRAY, Jr., of Cincinnati, Hamilton county, State of Ohio, have invented certain new and useful Improvements in Lathes for Turning Railroad-Car Axles; and I hereby declare the following to be a full, clear and exact description thereof, reference being had to the accompanying drawing making part of this specification.

Nature and Objects of Invention.

My invention relates to the form of axle-lathe having a "dead center" at each end, the axle being revolved by direct connection with the driving mechanism; and

It consists—

First, in a peculiar device for so governing and operating the "tool-rest" that the tool cuts both the taper and straight parts of the axle automatically, with no adjustment during the operation except the simple one of moving the rest in and out for the different diameters.

Second, in a peculiar construction of "dog" for driving the axle, which compensates for inaccuracies in the construction of the lathe, and always preserves so uniform a pressure upon the axle in driving it that it is never "sprung" or forced out of the central line.

Description of the Accompanying Drawing.

Figure 1 is a side elevation of an axle-lathe embodying my invention.

Figure 2 is an end view of the same.

Figure 3 is an axial section through the driving-head, which surrounds the axle.

Figure 4 is a perspective view of the driving-dog.

Figure 5 is a plan of the lathe-shears and carriage, showing the device for operating the tool-rest.

Figure 6 is a cross-section of a portion of the shears, showing how the device which operates the tool-rest is connected with the shears.

Figure 7 is a perspective view of the tool-stock, showing the manner of connecting the "pad" thereto.

General Description.

The lathe-bed A is fitted with two sliding blocks, B B', which carry the dead centers C C', upon which the axle D revolves.

The bed is also fitted with two carriages, E E', carrying the cross-sliding tool-rests F F', the carriages being moved longitudinally by power with screw G, or by hand with hand-wheels H, in the ordinary way.

A central block or carriage, I, is fitted to the bed of the lathe, as shown, in which is journaled the hollow shaft J, through which the axle D passes.

This hollow shaft or box J is constructed with a spur-gear wheel, K, outside of the journal.

Upon the face of this wheel a plate, L, is fitted, which forms a part of the driving-dog, the other part, M, being secured, as shown, to the axle.

Pins or studs, N, project from the plate to form a driving connection with the arms *m m'* of the dog M.

The plate L is constructed with "slotted" or elongated holes, P, through which the bolts Q pass, which secure the plate to the shaft J.

The bolts Q are "shouldered bolts," as shown in dotted lines in fig. 3, in order that they may be screwed "home" without bringing the heads *q* too close to permit the free oscillation of the plate L in the slots P.

The oscillation of the plate L in the slots P in the operation of the lathe serves to enable the studs or pins N to press with equal force upon the arms *m m'*, no matter how the part M may be adjusted upon the axle, and to compensate, by sliding backward and forward, in turning round for any inaccuracies in the adjustment of the center of the shaft J with relation to the centers C C' of the lathe.

Thus it will be seen that the axle cannot be sprung out of line by one-sided pressure upon the dog M at any point in the revolution of the axle or lathe.

The axle is driven by pinion R and shaft S, the latter being journaled in the support I and driven by suitable connections from cone belt-pulley T.

At the back of the lathe-bed, near each end, a plate, U, is secured, which, except for a short distance, is parallel with the bed, the exception being a beveled or tapering portion, which is located immediately opposite to the part of the axle which is required to be turned tapering for the reception of the car-wheel.

In the drawing the degree of taper, both on the plates U and the axle, is greatly exaggerated, in order that it may be clearly exhibited. The degree of taper necessary in practice is so slight as to show in a drawing a scarcely-perceptible divergence from a straight line.

A metallic pad, V, rests against each plate U, which connects with the tool-rests F and F' by means of side rods W, cross-head X, and central screw Z.

The pad V is forced against the plate U so as to compel the pad to follow the configuration of the plate U by means of coiled springs *a a'* on the side rods W.

In the operation of the lathe, as the carriages E E' are moved longitudinally the tool-rests F F' are adjusted for the straight and tapering portions automatically by the device described, and it is simply necessary, in the turning of the axle, to move the rests F F' in and out by means of the screws Z and handles *b* for the different diameters.

The carriages E E' are detachably connected to the "lead-screw" by means of the customary sliding half-nuts operated by clutch-plates G'.

As it is necessary that one workman alone should operate the lathe at both ends, it may be necessary (until the operator is sufficiently skilled in starting one cut behind the other in time and stopping on time) to attach projections to the lathe which are stationary and adjustable, against which the clutches G' strike in such a manner as to open the nuts and thus prevent damage to the lathe by accidental overrunning.

Claims.

1. In the described combination with the sliding tool-

rest F' or F", the plate U, pad V, side rods W, cross-head X, springs a a', and central screw Z, connected and operating substantially as and for the purpose specified.

2. In combination with the hollow shaft J and dog M of the axle, the slotted dog-plate or driver L P N, secured and operated substantially in the manner and for the purpose specified.

In testimony of which invention I hereunto set my hand.

G. A. GRAY, JR.

Witnesses:

J. L. WARTMANN,
ELITHA F. LAYMAN.